

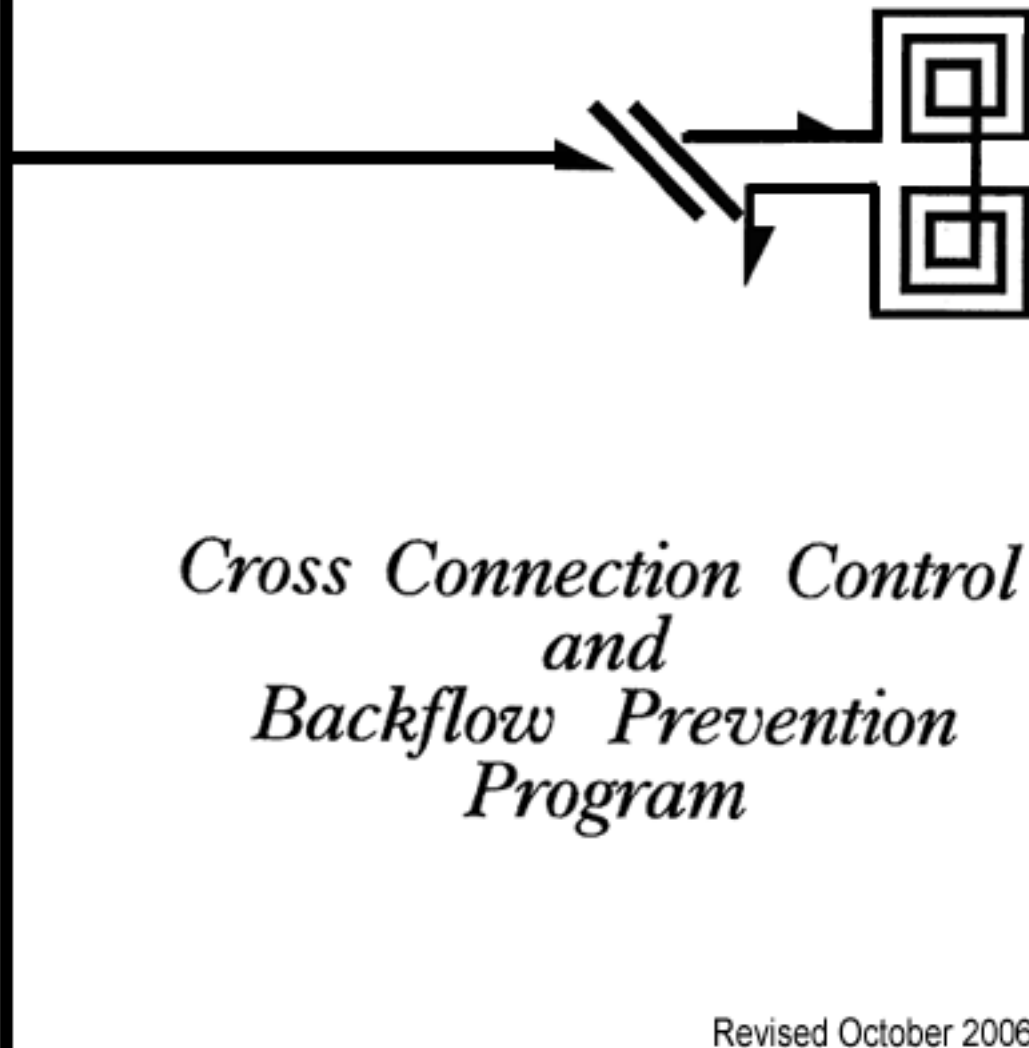

SAN ANTONIO WATER SYSTEM



Cross Connection Control and Backflow Prevention Program

Revised October 2006

**San Antonio Water System Board of Trustees
of San Antonio, Texas**

**San Antonio Water System
Cross-Connection Control and
Backflow Prevention Program**

**July 1974
Revised May 1976
Revised August 1977
Revised May 1979
Revised October 1997
Revised July 1999
Revised October 2006**

Table of Contents

For

Cross-Connection Control and

Backflow Prevention Program

Section 1 – Introduction

- 1-1. Introduction
- 1-2. Principles
- 1-3. References

Section 2 – Definitions

- 2-1. General Words and Terms
 - 2-1.1 Approved Air Gap Separation
 - 2-1.2 Approved Backflow Prevention Method
 - 2-1.3 Approved By-pass
 - 2-1.4 Approved Check Valve
 - 2-1.5 Approved Double Check Detector Assembly (DCDA)
 - 2-1.6 Approved Double Check Valve Assembly (DC)
 - 2-1.7 Approved Pressure Type Vacuum Breaker
 - 2-1.8 Approved Reduced Pressure Backflow Prevention (RP) Assembly
 - 2-1.9 Approved Spill Resistant Pressure Type Vacuum Breaker
 - 2-1.10 Backflow
 - 2-1.11 Backpressure
 - 2-1.12 Backsiphonage
 - 2-1.13 Board
 - 2-1.14 Certification Classification
 - 2-1.15 City
 - 2-1.16 Contamination
 - 2-1.17 Cross-Connection
 - 2-1.18 Customer
 - 2-1.19 Developmental Services Department
 - 2-1.20 Director of Pipeline Inspections
 - 2-1.21 Licensed Backflow Prevention Assembly Tester
 - 2-1.22 Local Health Officer
 - 2-1.23 Premises
 - 2-1.24 Private Water Supply
 - 2-1.25 Service Line
 - 2-1.26 Water Service

Section 3 – Responsibilities

- 3-1.** General
- 3-2.** Health Agencies
- 3-3.** San Antonio Water System
- 3-4.** Department of Development Services,
City of San Antonio
- 3-5.** Licensed Backflow Prevention Assembly Tester
 - 3-5.1.1. Responsibility of Licensed Tester
 - 3-5.1.2. Inspection and Repair
 - 3-5.1.3. Procedure and Equipment
- 3-6.** Customer Responsibility

Section 4 - Procedures

- 4-1.** General
- 4-2.** Type of Protection Required
 - 4-2.1 Principle
 - 4-2.1.1 Air Gap Separation
 - 4-2.2 Criteria
 - 4-2.3 Selection of Protective Device
 - 4-2.3.1 Type of Business or Establishment - Inside City Limits
 - 4-2.3.3 Private Well Supply
 - 4-2.4 Backflow Protection for Fire lines
 - 4-2.4.1 Classifications and Requirements for Backflow Protection on Fire lines
 - 4-2.4.2 Tri-Water System or Circulated Closed-Loop System
 - 4-2.4.3 Backflow Prevention Approved
 - 4-2.5 Single Check Valve
- 4-3.** Procedures on New Facilities
 - 4-3.1 Building Permit
 - 4-3.2 Water Service Application
 - 4-3.3 Customer Service Inspections
- 4-4.** Procedures on Existing Facilities
 - 4-4.1 Inspection Procedure – Water Use Survey
 - 4-4.2 Department of Development Services
 - 4-4.3 San Antonio Water System Counter Services
 - 4-4.4 San Antonio Water System Customer Service Department
- 4-5.** Installation
 - 4-5.1 Size of Backflow Prevention Assembly
 - 4-5.2 By-pass Policy
- 4-6.** Non-compliance
- 4-7.** Records and Tests
 - 4-7.1 Time Schedule
 - 4-7.2 Testing by SAWS Personnel
- 4-8.** Cross-Connection Control Liaison Committee

4-9. Costs

4-10. Process Flow Charts

4-10.1 Cross-Connection Control and Backflow Prevention Program Guidelines

4-10.2 Customer Service Inspection Process

Appendix A – Backflow Prevention Assembly Installation Standards

Appendix B – Backflow Protection for Water Hauling Equipment-Mixing Tanks

Appendix C – Backflow Prevention Standard Drawing Information

Cross-Connection Control and Backflow Prevention Program

Guidelines

San Antonio Water System San Antonio, Texas

Section 1 – Introduction

1-1. Introduction

The purpose of the Cross-Connection Control and Backflow Prevention Program is to provide guidelines for the implementation of the San Antonio Water System's (SAWS) Board of Trustees Regulations for Water Service, System Extension, and Service Line Installation and Criteria for Water Supply and Distribution within its service area as established by the Public Utility Commission of Texas and appropriate provisions of the City Code of the City of San Antonio all of which are promulgated for the purpose of protecting the water supply of San Antonio Water System from contamination by isolating within its customer's internal distribution system any contaminates which could Backflow into the public water supply system. Furthermore, the program establishes guidelines for the maintenance of a continuing program of Cross-Connection control and backflow prevention. Failure, refusal or inability on the part of the customer to comply shall constitute grounds for refusing or discontinuing water service. The desired control is one of containment of the actual or potential hazard within the customer's premise.

1-2. Principle

The overall program is based on the experience obtained as a result of extensive field surveys which have revealed that after initial construction, uncontrolled Cross-Connections are made within many existing establishments to which San Antonio Water System service is being provided. The desired control is one of containment of the actual or potential hazard within the customer's premises. The hazard is to be contained through the use of an air gap separation or in certain instances, backflow protection assemblies will be installed between the outlet side of the water meter and the first tap or tee. In some situations, backflow protection of the San Antonio Water System's distribution system can be accomplished at

the hazard point or through internal containment backflow prevention assemblies as outlined elsewhere in this program.

1-3. Reference

The following references are adopted and made a part of the Cross-Connection Control and Backflow Prevention Program.

- (1) The pertinent sections of the San Antonio Water System Board of Trustees Regulations for Water Service, System Extensions, and Service Line Installation, which prohibit a direct connection between the San Antonio Water System, and a customer service line which includes a Cross-Connection, and which may, therefore, result in a source of contamination of the San Antonio Water System. SAWS shall require appropriate backflow prevention arrangements for those facilities as provided for in the San Antonio Water System's Criteria where a potential health hazard exists. SAWS shall immediately discontinue service to any property where any unapproved connection or Cross-Connection exists, and service shall not be re-established until, the San Antonio Water System determines that the unsatisfactory condition has been corrected.
- (2) Those pertinent sections the of San Antonio Water System Criteria for Water Supply and Distribution in the City of San Antonio and its Extra-territorial Jurisdiction, which stipulate the type of backflow prevention assembly and the condition under which such a device shall be installed. These assemblies are outlined in Section 4 of this Program.
- (3) San Antonio City Code, Section 34-40. Cross-Connections with Water Mains Prohibited, which states, "(a) It shall be unlawful for any person to make or to maintain any Cross-Connection within the city or to allow any Cross-Connection to exist at any place under the control of any person. (b) The term Cross-Connection, as used in this section, is defined as any mechanical union or any hydraulic union which, under any condition, might pass water into the water supply system of the city from any other source."
(Code 1950, § 62-14; Code 1959, § 41-22)
- (4) San Antonio City Code, Section 34-41. Disconnection for noncompliance, which states, "It shall be the duty of the manager of the water supply system of the city to disconnect the city service from any place where the provisions of this article are violated,

whether inside or outside the city.”(Code 1950, § 62-15; Code 1959, § 41-23)

- (5) San Antonio City Code, Section 24.1. Uniform Plumbing Code, Paragraph (a) which states, “The 2006 edition (latest revision) of the Uniform Plumbing Code of the International Association of Plumbing and Mechanical Officials, as amended hereinafter, is hereby adopted as the Plumbing Code of The City of San Antonio.” The Uniform Plumbing Code 2006 chapter 6, section 602.3 Cross-Connection Control states: No person shall make a connection or allow one to exist between pipes or conduits carrying domestic water supplied by any public or private water service system, and any pipes, conduits, or fixtures containing or carrying water which has been used for any other source or containing or carrying water which has been used for any other purpose whatsoever, unless there is provided a backflow prevention device approved for the potential hazard.

Chapter 6, Section 603.0 Cross-Connection Control

Cross-connection control shall be provided in accordance with the provision of this chapter. No person shall install any water operated equipment or mechanism, or use any water treating chemical or substance, if it is found that such equipment, mechanism, chemical or substance may cause pollution or contamination of the domestic water supply. Such equipment or mechanisms may be permitted only when equipped with an approved backflow prevention device or assembly.

- (6) Occupational Safety & Health Administration - Federal Register, number 202 Part 2 Page 22234 sub-parts J General Environmental Control 1910.14.1 Sanitation which states that “(b) Water Supply- (2) Non-potable Water (ii) there shall be no Cross-Connection; open or potential, between system furnishing Non-potable water. (iii) Construction shall be such as to prevent backflow of containment water into a potable water system.”
- (7) U.S. Environmental Protection Agency - Cross-Connection Control Manual (1972 Edition or latest revision) EPA
- (8) Texas Commission on Environmental Quality (TCEQ) Rules and Regulations for Public Water Supply Systems, Sec. 290.44 (h) (1) Backflow, Siphonage - No water connection from any public drinking water supply system shall be allowed to any residence or establishment where an actual or potential contamination hazard exists unless the public water facilities are protected from contamination. The containment air gap is sometimes impractical and instead, reliance must be placed on individual “internal” air

gaps or mechanical backflow prevention devices. Under these conditions, additional protection shall be required at the meter in the form of a backflow prevention assembly (in accordance with AWWA Standards C510 and C511, and AWWA Manual M14) on those establishments handling substances deleterious or hazardous to the public health. The water purveyor need not require backflow protection at the water service entrance if an adequate Cross-Connection control program is in effect that includes an annual inspection and testing by a licensed backflow prevention device tester. It will be the responsibility of the water purveyor to ensure that these requirements are met.

Cross-Connection Control and Backflow Prevention Program

Guidelines

San Antonio Water System San Antonio, Texas

Section 2 – Definitions

2-1. General Words and Terms

2-1.1. Approved Air Gap Separation is the unobstructed vertical distance through the free atmosphere between the lowest opening from any pipe or faucet supplying water to a receiving tank and the flood rim of the tank. An approved air gap separation shall be at least twice the diameter of the supply pipe measured vertically above the overflow rim of the vessel, and in no case shall the gap be less than one inch.

2-1.2. Approved Backflow Method is one that has been reviewed and approved by SAWS, and which includes the following types of Backflow Protection; approved air gap separation, approved reduce pressure principle backflow prevention assembly, approved double check valve assembly, and approved pressure-type vacuum breaker.

2-1.3. Approved By-pass is a connection from the San Antonio Water System's side of an approved device to the customer side of the device for the purpose of diverting the water around the backflow preventer while it is being repaired or replaced. All By-passes on backflow prevention devices will themselves include provisions for backflow prevention as described within this program.

2-1.4. Approved Check Valve is a check valve that seats readily and completely. It must be carefully machined to save free moving parts and assure water tightness permitting no leakage in a direction reverse to the normal flow. The valve must be weighted or spring loaded to one psi in the direction of

flow. The face of the closure element and valve seat must be of bronze composition or other non-corrodible material which will seat tightly under all prevailing conditions of field use. Pins and bushings shall be of bronze or other non-corrodible, non-sticking material, machined for easy, dependable operation. The closure element normally referred to as a clapper, shall be internally weighted or otherwise internally equipped to promote rapid and positive closure in all sizes where this feature is obtainable.

2-1.5. Approved Double Check Detector Assembly (DCDA) The term “double check-detector backflow prevention assembly” shall mean a specifically designed assembly composed of a line-sized approved double check valve assembly with a By-pass containing a specific water meter and an approved double check valve assembly. The meter shall register accurately for only very low rates of flow up to three gpm (gallons per minute) and shall show a registration of all rates of flow. This assembly shall only be used to protect against a non-health hazard (i.e., pollutant). The DCDA is primarily used on fire sprinkler systems. The entire assembly shall meet the design and performance specifications and full approval, lab and field, of a recognized and approved testing agency for backflow prevention assemblies, e.g., University of Southern California’s Cross-Connection Control or American Water Works Association.

2-1.6. Approved Double Check Valve Assembly (D/C) is an assembly composed of two single, independently acting, approved check valves, including resilient seating shut-off located at each end of the assembly and suitable connections for testing the water tightness of each check valve. The entire assembly shall meet the design and performance specifications and full approval, lab and field, of a recognized and approved testing agency for backflow prevention assemblies, e.g., University of Southern California’s Cross-Connection Control or American Water Works Association.

2-1.7. Approved Pressure Type Vacuum Breaker is an assembly containing a single-loaded check valve and an air inlet valve which shall admit air whenever the pressure within the body of the assembly is reduced so that there is a tendency toward backsiphonage. The body of the assembly must be equipped with two tight closing shut off valves, one immediately upstream from the body and one immediately downstream of the body, and two properly located test cocks. It is designed to operate under pressure for long periods of time without inoperative, making it possible to isolate a lawn sprinkler line from the potable system. It must be installed such that it could never be subject to backpressure. The entire assembly shall meet the design and performance specifications and full approval, lab and field, of a recognized and approved testing agency for backflow prevention assemblies, e.g., University of Southern California’s Cross-Connection Control or American Water Works Association.

2-1.8. Approved Reduce Pressure Backflow Prevention (RP) Assembly is an Assembly of two independently operating approved check valves with an automatically operating differential relief valve between the two check valves, resilient seating shut-off valves on either side of the assembly, plus four properly located test-cocks for the testing of the check and relief valves. The entire assembly shall meet the design and performance specifications and full approval, lab and field, of a recognized and approved testing agency for backflow prevention assemblies, e.g., University of Southern California's Cross-Connection Control or American Water Works Association. The device shall operate to maintain the pressure in the zone between the check valves at a level two psi less than the pressure on the public water supply side of the device. At cessation of normal flow, the pressure between the check valves shall be two psi less than the supply pressure. In case of leakage of either check valve, the differential relief valve shall operate to maintain this reduced pressure by discharging to the atmosphere. When the inlet pressure is two psi or less, the relief valve shall open to the atmosphere. To be approved, these devices must be installed above-ground.

2-1.9. Approved Spill Resistant Pressure Type Vacuum Breaker is an assembly containing a single-loaded check valve and an air inlet valve which shall admit air whenever the pressure within the body of the assembly is reduced so that there is a tendency toward backsiphonage. The body of the assembly must be equipped with two tight closing shut-off valves, one immediately upstream from the body and one immediately downstream of the body, and one properly located test cock and vent valve. It is designed to operate under pressure for long periods of time without becoming inoperative, making it possible to isolate a lawn sprinkler line from the potable system. It must be installed such that it could never be subject to backpressure. The entire assembly shall meet the design and performance specifications and full approval, lab and field, of a recognized and approved testing agency for backflow prevention assemblies, e.g., University of Southern California's Cross-Connection Control or American Water Works Association.

2-1.10. Backflow with in the scope of this program is the reverse flow of water through a service connection, i.e., flowing from the customer's side of the service connection into the distributing pipelines of the potable water system. Backflow may occur under either a backpressure or backsiphonage conditions.

2-1.11. Backpressure is that pressure in the customer's system that exceeds that in the public water system.

2-1.12. Backsiphonage occurs when the pressure in the public water system becomes less than that of the customer's system due to a vacuum or partial vacuum in the public system.

2-1.13. Board is the San Antonio Water System Board of Trustees of the City of San Antonio, Texas, created by City Ordinance No. 75686, adopted April 30, 1992, and is sometimes referred to as the San Antonio Water System (SAWS).

2-1.14. Certification Classification-Licensing Classification is divided into the following categories and the testers are not considered to be employees, agents or representatives of the San Antonio Water System.

(1) General Licensed Tester means qualified to test any type or make of backflow prevention device. Tester must be a journeyman plumber working for a master plumber. (Not to include testing on fire line devices)

(2) Limited Licensed Tester means qualified to test all types of backflow prevention devices at the premises owned or controlled by an individual or company.

(3) Licensed Irrigator Tester is approved to test assemblies located on all irrigation systems.

(4) Licensed Fire Line Tester is approved to test assemblies on all fire lines. Must be registered by State Fire Marshall's office.

2-1.15. City is the City of San Antonio, Texas.

2-1.16. Contamination is the presence of any foreign substance (organic, inorganic, radiological or biological) in water which tends to degrade its quality so as to constitute a hazard or impair the usefulness of the water.

2-1.17. Cross-Connection an unprotected actual or potential connection, mechanical or hydraulic union between a potable water system and a recycled or other non-potable water system that would allow non-potable water to pass into the potable water supply.

2-1.18. Customer is any person to whom water is sold or furnished from the City water supply by the San Antonio Water System. (Can mean either owner or lessee).

- 2-1.19.** Development Services Department is the department for all permitting services for the City of San Antonio.
- 2-1.20.** Director of Pipeline Inspection is the Director of the Pipeline Inspections Department of SAWS, or his/her authorized representative.
- 2-1.21.** Licensed Backflow Prevention Assembly Tester is any person that has received authorization from the Texas Commission on Environmental Quality (TCEQ) by successfully completing a TCEQ approved certification school. The tester will be approved to test assemblies as outlined in section 2-1.26. Manufacturer's representatives who have completed a TCEQ approved Certification School will be accepted as certified backflow prevention assembly tester for the assemblies produced by the manufacture they represent. The Director of Pipeline Inspections will maintain a current list of approved testers and will honor any request for same. The applicant must renew his certification with TCEQ and copy the San Antonio Water System every three years, however, the tester may be removed from the "approved list" by SAWS for improper testing or reporting for a period of one year.
- 2-1.22.** Local Health Officer is the San Antonio Metropolitan Health District Director, his/her assistant, authorized deputy, or any other person appointed as Health District Director of the City of San Antonio.
- 2-1.23.** Premise is an integrated land area including improvements thereon undivided by public thoroughfares or water distribution mains of the City of San Antonio and where all parts of the premises are operated under the same management.
- 2-1.24.** Private Water Supply is any water supply including a well on or available to the premises other than the city water supply. These auxiliary waters may include water from another purveyor's public water supply or any natural source such as a well, spring, river, ponds, etc.
- 2-1.25.** Service Line is a pipe extending from a water distribution main installed in a permitted location adjacent to the property of a customer and terminating at the San Antonio Water System's water meter for the purpose of providing water to a customer for ordinary metered water service. Service line connections also include water service connections from fire hydrants and other temporary or emergency water service lines from the public water system.

2-1.26.

Water Service is the complete range of activities of SAWS in combination with total facilities utilities used by SAWS to provide for the delivery of and to deliver potable water and water for fire protection in adequate quantity and pressure to the premise of the customer.

Cross-Connection Control and Backflow Prevention Program

Guidelines

San Antonio Water System
San Antonio, Texas

Section 3 – Responsibilities

3-1. General

The implementation of a program for the effective control of Cross-connections and backflow prevention requires the full cooperation of all concerned: the state and local health agencies, the water purveyor, the Development Services Department of Building Inspections, the Licensed Backflow Prevention Assembly Tester and the customer.

3-2. Health Agencies

The “Rules and Regulations for Public Water Systems” of the Texas Commission on Environmental Quality govern the design, construction, operation and maintenance of Public Water Supplies.

290.44 (h) Backflow, Siphonage

“No water connection from any public drinking water supply system shall be allowed to any residence or establishment where an actual or potential contamination hazard exists unless the public water facilities are protected from contamination.”

The containment air gap is sometimes impractical and instead, reliance must be placed on individual “internal” air gaps or mechanical backflow prevention devices. Under these conditions, additional protection shall be required at the meter in the form of a backflow prevention assembly (in accordance with AWWA standards C510 and C511, and AWWA manual M14) on those establishments handling substances deleterious or hazardous to the public health. The water purveyor need not require backflow protection at the water service entrance if an adequate Cross-connection control program is in effect that includes an annual inspection.

290.44 (h) (2)

“No water connection from any public drinking water supply system shall be made to any condensing, cooling or industrial process or any other system of non-potable usage over which the public water supply system officials do not have sanitary control, unless the said connection is made in accordance with the requirements of paragraph (1) of this subsection. Water from such systems cannot be returned to the potable water supply”

290.44 (h) (4)

“All backflow prevention assemblies that are required according to this section and associated table located in 290.47(i) of this title shall be tested upon installation by a recognized backflow prevention assembly tester and certified to be operating within specifications. Backflow prevention assemblies which are installed to provide protection against health hazards must also be tested and certified to be operating within specifications at least annually by a recognized backflow assembly tester.

290.44 (h) (4) (B)

“Gauges used in the testing of backflow prevention assemblies shall be tested for accuracy annually in accordance with the University of Southern California’s Manual of Cross-connection Control or American Water Works Association Recommended Practice for Backflow Prevention and Cross-connection Control (Manual M-14). Public water systems shall require testers to include test gauge serial numbers on “Test and Maintenance” report forms and ensure testers have gauges tested for accuracy.

290.44 (h) (4) (C)

“A Test Report must be completed by the recognized backflow prevention assembly tester for each assembly tested. The signed and dated original must be submitted to the public water supplier for record keeping purposes. Any form which varies from the format specified in Appendix F of this title (relating to Backflow Prevention Assembly Test and Maintenance Report) must be approved by the executive director prior to being placed in use.”

290.44 (h) (1) (B) (ii)

“Copies of all such inspection and test reports must be obtained and kept on file by the water purveyor.”

290.44 (h) (5)

“The use of a backflow prevention assembly at the service connection shall be considered as additional backflow protection and shall not negate the use of backflow protection on internal hazards as outlined and enforced by local plumbing codes.”

Texas Commission on Environmental Quality (TCEQ) is the primary enforcing agency of the “Rules and Regulations” for Public Water Systems for all public water systems in the state of Texas.

3-3. San Antonio Water System

San Antonio Water System has the responsibility of providing its customers with drinking water in accordance with its status as a Public Water System. San Antonio Water System’s responsibility begins at the production facilities and includes all of the public distribution systems, including the service line and ends at the point of delivery to the customer’s water system which is the customer’s side of the water meter. To ensure adequate protection in individual cases the Director of Pipeline Inspections or his representative is required to determine the degree of hazard to the public potable water system. When it is determined that a backflow prevention assembly is required for the protection of the public water system the water purveyor will require the customer, at his expense, to properly install an approved backflow prevention assembly at each service connection and/or at the hazard point, to be tested annually or more often in those instances where successive inspections indicate repeated failure, and to properly repair and maintain such assembly or assemblies. The Director of Pipeline Inspections will establish a Cross-connection Control Group within the Engineering Department for the purpose of implementing and monitoring of this program. The Backflow Prevention Supervisor will administer the program and will act as the San Antonio Water System’s representative on the Cross-connection Liaison Committee. As stated in definition 2-1.25, the Director of Pipeline Inspections shall maintain a current list of Approved Backflow Prevention Assembly Testers. It shall be the responsibility of the San Antonio Water System’s Backflow Prevention Supervisor to enforce the Cross-connection Control regulations by directing competent inspections of installations of approved backflow prevention assemblies, in accordance with these guidelines on both new and existing facilities. He shall assure that proper records are maintained on all installations of approved backflow prevention assemblies, in accordance with these guidelines on both new and existing facilities.

He shall assure that proper records are maintained on all installations and shall initiate action as appropriate to prohibit or discontinue service to any customer who maintains actual or potential sanitary hazards in his internal potable water system (downstream from the meter) or whose plumbing is susceptible to Cross-connections unless adequate protection against backflow is provided.

3-4. Development Services Department of the City of San Antonio

The Plumbing Inspection Section of the Development Services Department has the responsibility to assure compliance with all Plumbing Codes pertaining to Cross-connections, i. e., and proper installation of the customer's building plumbing including the connection line to the public potable water supply. It is the responsibility of the Development Services Department to coordinate all building permit approvals with the San Antonio Water System for the total containment program. The Director of Building Inspections will appoint a representative to the Cross-connection Control Liaison Committee.

3-5. Certified Backflow Prevention Assembly Tester

3-5.1. Responsibility of Licensed Tester

When employed by a customer, a Licensed Backflow Prevention Assembly Tester is responsible for the test, repair, overhaul, and maintenance of backflow prevention assemblies.

3-5.2. Inspection and Repair

The licensed tester will be responsible for making competent inspections and repairing or overhauling backflow prevention assemblies and making reports of such repair to the customer in accordance with the Test and Maintenance Report Form. He/she shall include in the report a list of materials or replacement parts used, and he/she shall be equipped with and be competent to use all necessary tools, gauges, manometers, and other equipment necessary to properly test, repair, and maintain backflow prevention assemblies. It will be his/her responsibility to assure that parts recommended by the manufacturer of the assembly being repaired are used in the repair or replacement of parts in a backflow prevention device. It is extremely important that SAWS be made aware of any malfunctioning assembly within 24 hours.

3-5.3. Procedure and Equipment

It will be the licensed tester's responsibility not to change the design, material, or operational characteristics of an assembly during repair or maintenance without prior approval of SAWS. All work performed by his/her assistants shall be performed in his/her presence and under his/her jurisdiction. Each applicant for certification as a tester of backflow prevention assemblies shall furnish evidence to show that he/she has available the necessary tools and equipment to properly test such assemblies. The serial number of his/her test kit shall be on record with the San Antonio Water System and the test gauge must be tested when purchased and annually or more frequently as required by San Antonio Water System. The gauge must be maintained to a + or - 2% (.3 PSID) accuracy. The tester shall be responsible for the competency and accuracy of all tests and reports prepared by him/her and for the work done by any persons under his/her jurisdiction. In addition, gauge accuracy can only be achieved by a certified gauge Manufacture Representative or an ABPA Certified Proctor. Neither entity can test ones own gauges or for any other affiliated agency.

3-6. Customer Responsibility

The customer has the primary responsibility of preventing contaminants from entering his/her potable water system(s) or the public potable water system. The customer starts at the point of delivery from the public potable water system, and includes his/her complete internal water system. The customer, at his/her own expense, shall install, operate, test and maintain approved backflow prevention assemblies as required by the San Antonio Water System. Following any repair or overhaul of an assembly, the customer shall have it tested to ensure that it is in proper operating condition. Re-piping and relocation of an assembly shall have prior approval of the San Antonio Water System and shall be followed by re-testing. Tests, maintenance, and repair of backflow prevention assemblies shall be made by a licensed Backflow prevention assembly tester. The customer shall maintain accurate records of tests and repairs to backflow prevention assemblies and provide SAWS with copies of such records via the Test and Maintenance report form. Questions can be directed to:

Mr. Bruce Rathburn
Backflow Section
San Antonio Water System
2800 U.S. 281 North
Customer Service Center, Tower II
San Antonio, Texas 78212
(210) 233-3332

Cross-Connection Control and Backflow Prevention Program

Guidelines

San Antonio Water System
San Antonio, Texas

Section 4 – PROCEDURES

4-1. General

The procedure outlined herein is based on the afore-mentioned principle of containment of the potential or actual hazard within the customer's premises. Proposed deviations or exceptions may be submitted to the San Antonio Water System's Pipeline Inspection Department. Should a customer refuse the right of entry of the San Antonio Water System's representative(s) for the purpose of a water use survey or backflow prevention assembly inspection, the SAWS must assume maximum hazard and therefore require the highest degree of protection on such a customer's service line.

4-2. Type of Protection Required

4-2.1. Principle

It is to be recognized that Cross-connections vary widely in degree of hazard. The degree of protection and the type of protection deemed necessary to prevent backflow and possible contamination of the San Antonio Water System's Criteria concerning Cross-connection Control and Backflow Prevention and it is further outlined in this section. Backflow may occur under many different pressure differentials, varying from so called vacuum to very high pressures. The protection afforded by an assembly depends upon its type and on its proper installation, testing and maintenance.

4-2.1.1. Air Gap Separation

An air gap installation separating the San Antonio Water System Water supply from the customer's internal water system is acceptable in all situations listed in these procedures so long as it is properly maintained. Initial installation of this type that were originally made in accordance with this program may be subsequently changed. As these separations are easily eliminated or by-passed, it shall be the prerogative of the San Antonio Water System Director of Pipeline Inspections to perform field surveys and to explicitly specify the additional protection of a mechanical assembly. This would result, for example, in the case of a repeated violator of air gap separation standards. The air gap separation must be located as close as practical to the water meter and normally all piping between the meter and the receiving tank shall be entirely visible.

4-2.2 Criteria

The selection of an appropriate backflow prevention assembly depends upon the degree of hazard involved and will be based on the following general criteria:

- A. Whether or not the assembly could ever be subject to backpressure due to the customer's internal pumping pressures or elevation differentials.
- B. The nature of the contaminating material under the most critical circumstances.
- C. The extent to which additions may be made to the plumbing systems at a later date which would affect the initial selection of the assembly.
- D. The frequency with which a water supply could be exposed to a hazardous condition.
- E. The degree of protection of the water supply as provided by the local plumbing code and as enforced by the local plumbing inspection department.

The San Antonio Water System Director of Pipeline Inspections, acting either personally or through SAWS Pipeline Inspection Department field representative, shall retain the final decision in individual cases. He may, in formatting his decision, obtain advice and recommendation of the Cross-connection Control Liaison Committee.

It is essential that all types of establishments listed below provide for the “containment” of contamination within their premise either by an air gap separation between the meter and the first tap or tee by having each of the internal plumbing facilities properly air gapped. If the “containment” air gap is impractical and reliance instead is placed on individual “internal” air gaps or vacuum breakers, the Director of Pipeline Inspections has the prerogative of requiring additional protection in the form of either a reduced pressure principle backflow prevention assembly on establishments handling substances deleterious to health, or a double check valve assembly backflow prevention device on those handling substances, which, if backflow occurred into the potable water lines, would cause the water to be aesthetically objectionable.

In limited instances, provisions for total containment backflow protection shall be reviewed to allow the backflow prevention assembly to be installed on an internal branch line. An example of Internal Containment backflow protection would be a combination fire and domestic water service from the city water main. The containment, domestic backflow protection would be installed immediately after the fire line tee. Additionally, the fire line shall be provided with backflow protection in accordance with 4-2.4 Backflow Protection for Fire Lines. Those establishments/businesses which can be considered for internal containment backflow protection are noted as such in the criteria list, 4-2.3.1. Director of Pipeline Inspections shall have final determination when internal containment backflow protection will be allowed.

4-2.3 Selection of Protection Device

The type of device or assembly selected is based on the degree of hazard determined. It will be determined by the Backflow Prevention Supervisor to require this added protection and shall be exercised after an individual review of each case. This review will include an on-site inspection of the establishment by his/her representative.

4-2.3.1 Type of Business or Establishment – Inside and Outside City Limits
Device Required

- A/G - Air Gap Separation
- R/P - Reduced Pressure Principle Backflow Prevention Assembly
- D/C - Double Check Valve Assembly
- DCDA - Double Check Detector Assembly
- P.T.V.B - Pressure Type Vacuum Breaker
- S.V.B. -Spill/Resistant Vacuum Breaker

Type of Establishment/ Business	Device Required	Type of Establishment/ Business	Device Required
Apartments/ Condominiums Four Stories or more	R/P	Photo Lab (More Than Two Machines)	R/P
Auxiliary Water Supply Recycled, Wells, etc.	Air Gap or R/P	Plating Plant	R/P
Belted Meter Installation (By Individual Review)	DCVA or R/P	Power Plant	R/P
Building – Four Stories or more	R/P	Commercial Businesses or Establishments (By Individual Review)	DCVA or R/P
Car Wash (internal containment option-within two feet of main water service entry into car wash)	R/P	Restricted Establishments (Military/Air Fields)	R/P
Fire Line (With Chemical Additive)	R/P	Sewage Treatment Plants	R/P
Fire Line (With Fire Hydrant – see 4.2.4.1)	DCDA	R/V Park (By Individual Review)	R/P

Fire Line (Without Fire Hydrant)	DCVA	Gated Community Dedicated Services (By Individual Review)	R/P
Food Processing/Packaging Plant	R/P	Cooling Tower, Heat Exchangers, Chillers	R/P
Greenhouse, Landscape and or Grass Farms	R/P	Stock Yard/Farm & Ranch (By Individual Review)	R/P
Hospital/Dental/Medical Facility	R/P	Schools-Colleges Universities (elementary school- individual review)	R/P
Jail	R/P	Transportation Terminal	R/P
Laboratory – Chemical or Clinical	R/P	Wholesale Connections (Planned Unit Develop)	R/P
Laundry and Dry Cleaning Plants-Retail (Internal Containment Optional)	R/P	Reduction Plant	R/P
Lawn Irrigation Systems	D/C-PTVB- SVB	Petroleum Processes and Storage Plant	R/P
Lawn Irrigation Systems (With Fertilizer Injector or alternative water source)	R/P	Manufacturing Processing Plant (Toxics)	R/P
Lease Space (two or More Single Service) Internal Containment Option-Inside City Limits	R/P	Beauty Saloon/ Parlors With Foot Spas (Individual Review)	R/P

Note: Other types of establishments or businesses may require protection via air gaps or backflow prevention assemblies depending on the equipment and/or plumbing arrangements utilized therein. These shall be considered individually, at the discretion of the Supervisor of Backflow Prevention or his/her representative.

4-2.3.2 Private Well Supply

Where a private well supply exists in addition to an active San Antonio Water System service, the Texas Commission in Environmental Quality “Rules and Regulations,” are applicable as follows:

*City Water Supply with
Private Well On-site*

Approved Air Gap or

Reduced Pressure Principle Assembly

4-2.4 Backflow Protection for Fire Lines

Fire Flow Meter: Installation will be looked at upon individual review

In the interest of protecting the public’s potable water supply from possible contamination, effective March 15, 1992, the San Antonio Water System began requiring backflow protection on all new fire-line installations. As in other situations encountered in Cross-connection control, the degree of backflow protection necessary for a particular fire protection system will depend on specific conditions present. Pressure losses across backflow prevention assemblies must be accompanied in the design or redesign of the fire protection system if it is to function properly. This factor is particularly important when redesigning existing fire protection systems. All backflow prevention assemblies shall be Underwriters/University of Southern California’s Foundation for Cross-connection Control and Hydraulic Research Laboratory listed. Backflow prevention assemblies detailed herein shall be constructed in accordance with the provisions set forth in the San Antonio Water System’s Backflow Prevention Assembly Installation Standards, revised in October, 1999, or latest revision.

Stagnant Water Rule: In the interest of protecting the public it was determined that any water service that remains in a static condition from property line to ending point that exceeds 100 linear feet would have the appropriate backflow prevention device installed within said footage.

4-2.4.1

Classification and Requirements for Backflow Protection on Firelines

	<u>TYPE OF FIRELINE</u>	<u>REQUIRED PROTECTION</u>
A.	Fireline with no chemical Additive and no additional Water supply- less than 100' total linear pipe footage of a fire system to the most remote head	No Requirement
B.	Fireline with no chemical Additive and no additional Water supply- greater than 100' total linear pipe footage of a fire system to the most remote head*	Double Check Valve Assembly
C.	Fireline with fire hydrant no chemical Additive and no additional Water supply- greater than 100' total linear pipe footage of a fire system to the most remote head	Double Check Detector Assembly
D.	Fireline with fire hydrant- no chemical Additive and no additional water supply- Less than 100' total linear pipe footage to the fire hydrant	Detector Check Valve SAWS Standard Drawing
E.	Fire protection system Utilizing chemical additives**	Air Gap Separation or Reduced Pressure Principle assembly
F.	Fire protection system with access to An auxiliary water supply **	Air Gap Separation or Reduced Pressure Principle assembly

*Systems under 50% or more renovations and those systems installing booster pumps shall include provisions to protect the potable water supply from stagnate water as outlined in Section 4-2.4.1.

**Systems with chemical loops and/or foam injection shall require a reduced pressure principle backflow prevention assembly at the loop or foam injection point, however; an

expansion chamber or relief valve will have to be installed to compensate for thermal expansion in accordance with the fire codes. The installation of reduced pressure principle assemblies for containment backflow protection on fire lines should be avoided and installed only in situations where chemical injection occurs prior to any taps or tees.

***Existing chemical loops and systems with access to an auxiliary water supply shall be retrofitted with approved backflow protection.

Note: On a project that reflects ingress/egress it will be looked at as right of way when determining the 100' stagnant water rule on fire line placement. Line of Demarcation will be determined upon individual review.

4-2.4.2 Tri-Water System or Circulated Closed-Loop System

“Tri-Water” or “Circulated Closed Loop System” will not be permitted, i.e., combination fire line, heating and cooling.

4-2.4.2.1 Full Flow Testing and/or Backflow Prevention Assembly Tear-down Requirements for Fire Lines

The San Antonio Water System requires backflow prevention assemblies installed on fire lines to be completely disassembled every five years minimum if full flow testing can not be accomplished. The assembly shall be cleaned and rubber parts replaced when deemed necessary by the backflow prevention assembly tester and/or manufacturer. Assemblies should be tagged by the tester to indicate the last tear-down date. The Backflow Prevention Section shall track individual assemblies over a five-year period to ensure provisions are met as established above – “Full Flow Testing and/or Tear-down Requirements.”

Exception: If within a five year period, the assembly has been completely disassembled and cleaned (repair parts replaced if necessary), the five-year tear-down period will begin at that time. In the annual testing process, a backflow prevention assembly found to be malfunctioning should be completely torn down.

4-2.4.2.2 Test and Maintenance Report Form for Fire Line Backflow Prevention Assemblies

Test and Maintenance Report Forms (T & M) forms used by fire line testers shall include statements which indicate the system has been placed back in operation upon completion of test. Additionally, the (T & M) form shall have a statement for the tester to check off which indicates a flow test was performed within the past twelve (12) months as established in NFPA 25 Section 9.6.2.2.

The tester will attach full flow documentation to the (T & M) when submitted to the SAWS Backflow Prevention Section.

4-2.4.3 Backflow Prevention Approval

Backflow preventer approval shall be obtained from the San Antonio Fire Department, 207-8249, and the Pipeline Inspection Department, Backflow Prevention Section of the San Antonio Water System, 233-3332, prior to installation. The installation shall conform to the attached guidelines. Please direct any questions or comments to the San Antonio Water System Pipeline Inspection Department – Backflow Prevention Section (210) 233-3332.

4-2.5 Single Check Valve

The single check valve is not considered to be an approved backflow prevention assembly and is used in limited instances such as for directional flow control.

4-3 **Procedures On New Facilities**

The requirement for installation of a backflow prevention assembly by a new customer of the San Antonio Water System shall be issued in conjunction with his/her request for water service from the San Antonio Water System's Counter Services Division or with his/her application through the Development Services Department of Building Inspections for a building permit. In either case, field inspection of the premises and some discussion with the owner or his/her representative may be necessary to determine what the actual or potential hazards are and therefore what the assembly requirement will be.

4-3.1 Building Permit

All mechanical layouts or building plans submitted to the City of San Antonio Development Services Department will be reviewed by a plumbing inspections division representative to assure compliance with the City's plumbing code. All mechanical layouts or plans will be stamped by the plumbing inspections department, to indicate containment backflow protection might be required and contact should be made to the San Antonio Water System Pipeline Inspection Department – Backflow Prevention Section for a determination.

4-3.2 Water Service Application

The customer's application for water service shall include a mechanical layout or general provisions as outlined in the SAWS Backflow Prevention Control Program. If the size and type of assembly is not shown, the San Antonio Water System Pipeline Inspection Department will so specify. Upon installation and testing of the approved backflow prevention assembly or Air Gap arrangement, a record of the installation will be made by the San Antonio Water System.

4-3.3 Customer Service Inspections

In accordance with the Texas Commission on Environmental Quality's rules which became effective January 1, 1997, a customer service inspection certificate shall be completed prior to providing continuous water service to new construction, on any existing service when the water purveyor has reason to believe that Cross-connections or other unacceptable plumbing practices exists, or after any material improvement correction or addition to the private plumbing facilities.

Outside the City Limits and in areas not having access to plumbing inspections, the San Antonio Water System will require a Certificate of Compliance (inspection form) to be completed by a Customer Service Inspector or Water Supply Protection Specialist prior to the San Antonio Water System providing continuous water service. The inspection shall include all backflow prevention assemblies installed on the various Cross-connection hazards. Inside incorporated cities and areas having access to plumbing inspections; the Texas Commission on Environmental Quality accepts the plumbing final as the Certificate of Compliance. The plumbing final must include provisions for Cross-connection control and backflow prevention and lead regulation compliance as outlined in national plumbing codes.

4-4 **Procedures On Existing Facilities**

In the case of an existing service, the following general procedures will be utilized.

4-4.1 Inspection Procedure – Water Use Survey

After complete premise inspection by the San Antonio Water System Backflow Prevention Inspector, a formal written notice advising of backflow prevention assembly requirement will be issued to the owner or lessee of an establishment or premise. The notice will also contain the following: List of Approved Assemblies, Set of Backflow prevention assembly installation standards and a list of Licensed Testers.

4-4.2 City of San Antonio Development Services Department of Building Inspections – Permit Approval

Plans submitted to the City of San Antonio Development Services Department for approval on plumbing modifications or additions to an existing establishment will be reviewed by the San Antonio Water System to determine the type of backflow preventer required for the entire establishment. The type of backflow preventer will be noted on the plans for approval: Notice of Requirement, a list of Approved Assemblies, Set of Backflow Prevention Installation Standards and list of Licensed Testers.

4-4.3 San Antonio Water System Counter Services

Any customer request for a change on an existing commercial service or on an existing residential service where the change is due to a lawn sprinkler installation will be routed through the Pipeline Inspection Department's Backflow Prevention Section to ensure compliance of Section 4-3 Procedure on New Facilities above.

4-4.4 San Antonio Water System's Customer Service Department

Each request for a new commercial service to be placed through an existing service connection will be reviewed by the Pipeline Inspection Department's Backflow Prevention Section to ensure compliance with this Cross-connection Control and Backflow Prevention Program.

4-5 **Installation**

The backflow prevention assemblies and air gap separation shall be installed in accordance with the Prevention Assembly Installation Standard, attached hereto.

4-5.1 Size of Device

This program does not regulate the size of backflow preventers. However, the containment backflow prevention assemblies required will generally be the same size as the meter requirement stipulated by the San Antonio Water System Requirements & Program Division. Backflow Prevention Assemblies must be sized in accordance with local plumbing code requirements. *Exception:* assemblies on irrigation systems.

4-5.2 By-pass Policy

If a By-pass is installed around the approved backflow prevention assembly, the distribution system must be protected from a backflow through this By-pass, i.e., it also will include a backflow preventer of the same type as the main service line backflow preventer. Though it need not be of the same size, it must be installed and tested in a similar fashion to the service line assembly so as to provide the same degree of protection as the main service line.

4-6 **Non-Compliance**

In any case of non-compliance or violation of the San Antonio Water System Criteria or the City Code, the San Antonio Water System Director of Pipeline Inspections shall disconnect or discontinue service to a non-complying customer subject to proper notice to the customer.

4-7 **Records and Tests**

In order to assure that backflow prevention assemblies continue to operate satisfactorily, it will be necessary that tests be conducted in accordance with desired performance standards. All tests and repairs shall be performed by a Licensed Tester. The original Test and Maintenance Report form will be completed by the Licensed tester and submitted to the San Antonio Water System Pipeline Inspection Department for record. It will be the responsibility of the customer to initiate the testing and any maintenance necessary and to submit written results to the San Antonio Water System Pipeline Inspection Department.

4-7.1 Time Schedule

All backflow prevention assemblies must be tested at the time of installation, at the time of any repairing or relocation and at the completion of each year of service.

4-7.2 Testing by San Antonio Water System

San Antonio Water System personnel may perform periodic tests on backflow prevention assemblies at random locations, as authorized in the latest edition of the Uniform Plumbing Code, so as to ensure that acceptable tests are being followed by the Licensed Tester. Additionally, assemblies will be randomly selected and tagged in a manner that will determine if the assembly has been tested as required.

4-8 Cross-connection Control Liaison Committee

The Cross-connection Control Liaison Committee will consist of personnel from the San Antonio Water System, a representative of the San Antonio Metropolitan Health District, a representative of the Plumbing Inspections at Development Services with the City of San Antonio, a Registered Professional Engineer, a Licensed Plumber, a Mechanical Engineer, a Licensed Irrigator, a Fire Line System Designer, and a representative of the Bexar Metropolitan Water District.

4-9 Costs

All costs associated with the subject program are to be borne by the customer. This includes the initial purchase of the backflow prevention assembly, its proper installation, testing and maintenance. Advisory assistance may be requested at any time from the San Antonio Water System Pipeline Inspection Department without charge.

4-10

Process Flow Charts

4-10.1

Cross-Connection Control and Backflow Prevention Process

San Antonio Water System
 Backflow Prevention
 Cross Connection and Backflow Prevention Control
 Program Guidelines



7/5/06
 4-10

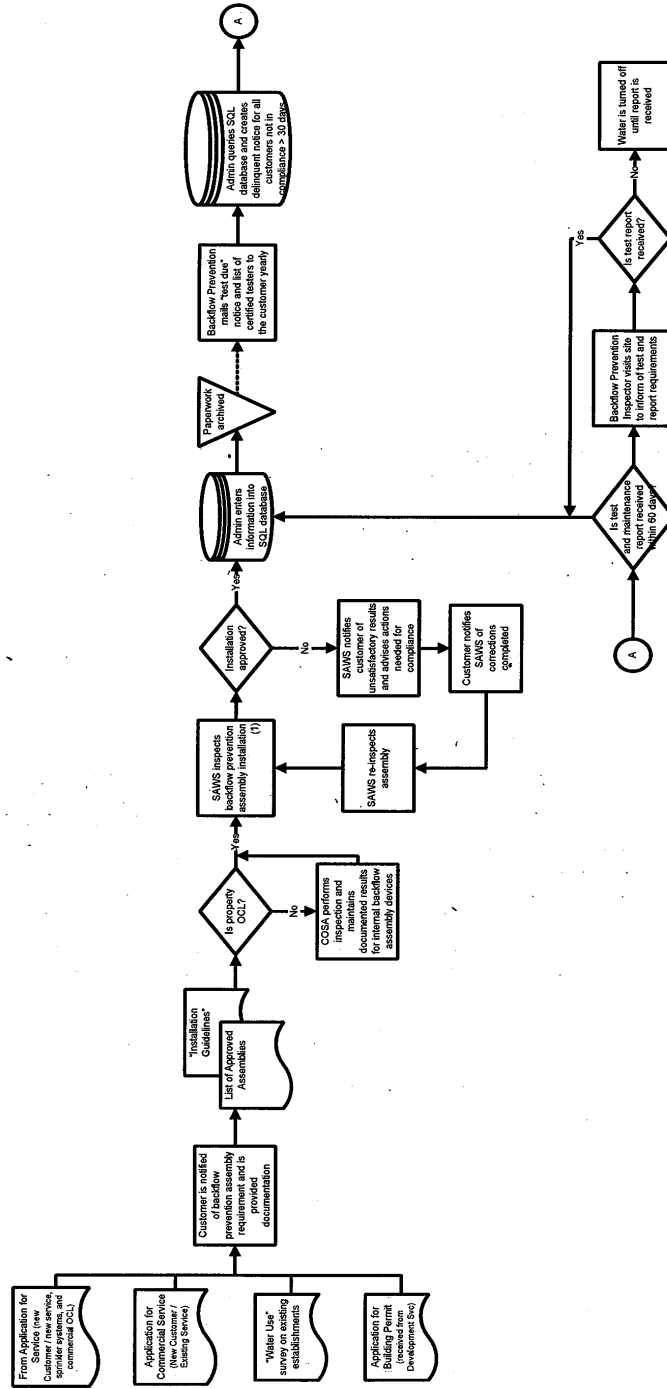

Notes:
 (1) For properties located outside the corporate limits (CCL) of San Antonio, SAMS inspects both the internal and external backflow prevention assemblies. For inside the corporate limits (CCL), the City of San Antonio inspects and maintains information on the internal backflow prevention assemblies.

6/27/06
4-12

San Antonio Water System
Backflow Prevention Section
Customer Service Inspection Process

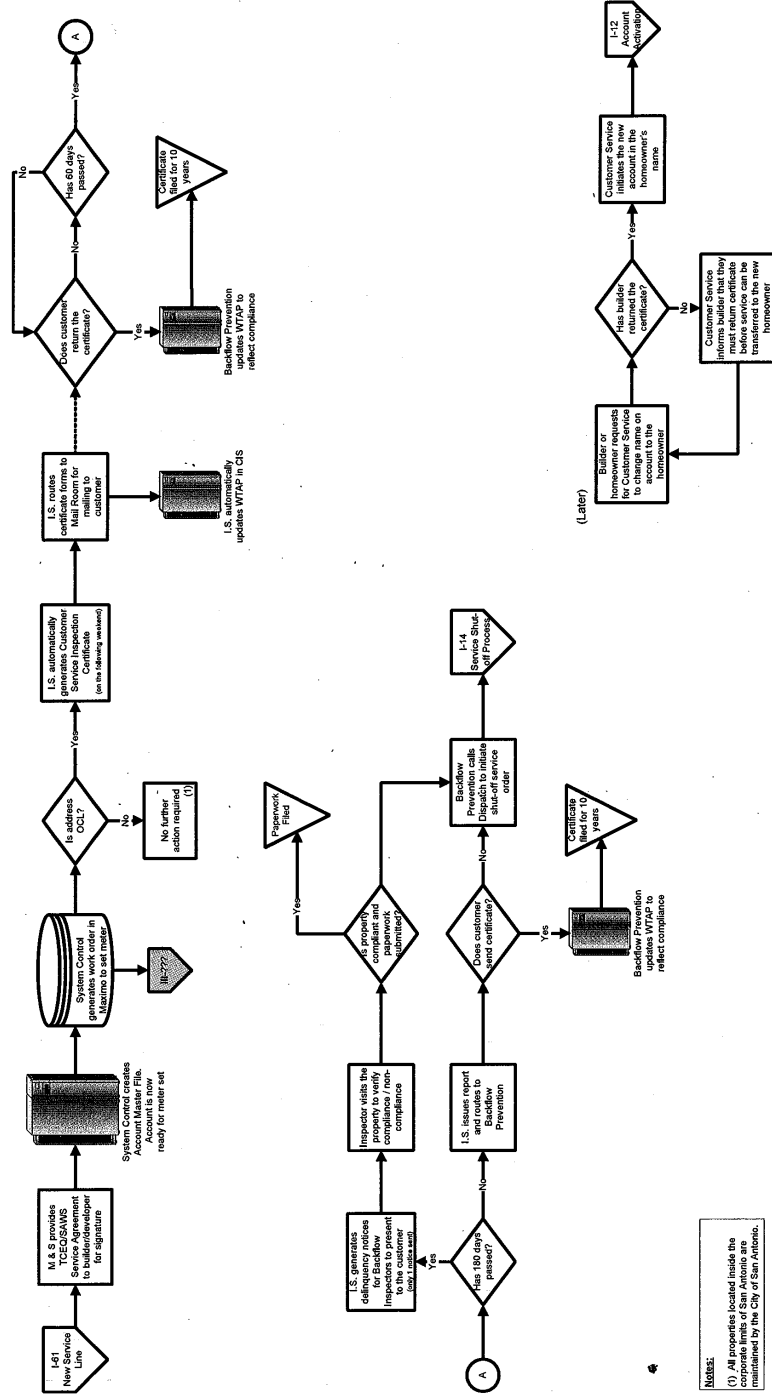

NOTES:
(1) All properties located inside the corporate limits of San Antonio are maintained by the City of San Antonio.

BACKFLOW PREVENTION ASSEMBLY INSTALLATION STANDARDS

All backflow prevention assembly installation shall be in accordance with the following Standards unless otherwise directed or approved by the San Antonio Water System (SAWS). These instructions are general guidelines and are subject to change without notice. Any Inquiries or requests should be directed to the San Antonio Water System's Backflow Prevention Section, at (210) 233-3332.

I. GENERAL INSTRUCTIONS

1. Assemblies will be installed in an accessible location to facilitate maintenance, testing and repair, and should be located no more than five feet above the floor or grade level. The backflow preventer must be installed between the meter and the owner's first tap or tee (total containment) unless otherwise approved. Internal containment will be approved for car washes, schools, retail laundries, and multiple lease spaces by individual review. In no instances will the assembly be allowed in the same vault with the San Antonio Water System's water meter. Containment assemblies on fire lines must be located within 100' (pipe length) of the property line.
2. Vault lids will be constructed in such a manner as to permit easy accessibility at all times by an individual. Vaults deeper than five feet shall be provided with a ladder permanently attached to a side wall. It is the contractor's and owner's obligation and responsibility to ensure OSHA regulations are adhered to in the construction of all vaults. Additionally, confined space regulations are to be consulted and followed in the testing and maintenance of the backflow prevention assemblies.
3. Before installing the assembly, pipelines should be thoroughly flushed to remove foreign material.
4. Test cocks must never be used as supply connections and must be plugged except when testing. Plugs must be non-ferris, e.g., brass, plastic, etc. Backflow preventers must be installed horizontally and in an upright position, unless full approval has been obtained from the University of Southern California or the American Water Works Association. Future testing and repair on backflow prevention assemblies require the indicated clearances to be provided regardless of test cock locations except for 1" or smaller double check valve assemblies that are repairable from the top, have test cocks on top of the assembly and not installed in concrete or asphalt.
5. All hot water heating systems should be evaluated before the backflow prevention assembly is installed to ensure that a Thermal Expansion Tank has been properly installed and in working condition. Future backflow prevention assembly tests should also include the testing of pressure relief valves.
6. In order to ensure that backflow prevention assemblies continue to operate satisfactorily, it will be necessary that they be tested at the time of installation and on an annual basis thereafter. Such tests will be conducted in accordance with SAWS performance standards and field test procedures as prescribed by the American Water Works Association or the University of Southern California. The Backflow Prevention Section shall provide appropriate "test and maintenance" report forms.
7. The Backflow Prevention Section will inspect all containment installations, i.e., located between the water meter and the owner's first tap or tee.
8. All costs entailed in the subject program are to be borne by the customer. This includes the initial purchase of the backflow preventer, its proper installation, testing and maintenance. Both containment and internal isolation backflow preventers must be maintained in good working condition.

II. INSTALLATION OF REDUCED PRESSURE PRINCIPLE BACKFLOW PREVENTERS

Reduce pressure principle backflow preventers will be installed above ground.

(Fig. A) The unit should be placed at least 12 inches (12") plus diameter of pipe above the finish grade to allow clearance for repair work. A concrete slab at finish grade is recommended. Proper drainage should be provided for the relief valve and may be piped away from the location, provided it is readily visible from above grade and the relief valve is separated from the drain line by a minimum of double the diameter of the supply line. A modified vault installation may be used if constructed with ample side clearances. (Fig. B) Freezing can be a problem in this area and precautions should be taken to protect above ground installations. (See General Instructions, page 1).

ABOVE GROUND INSTALLATION

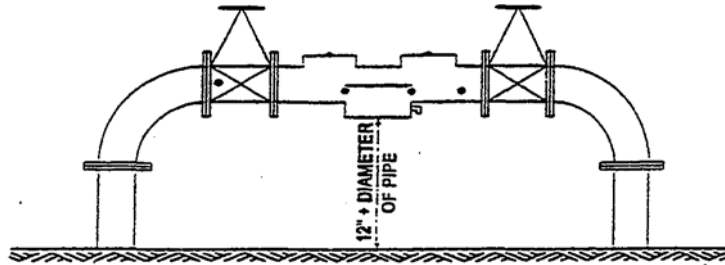

FIG. A

MODIFIED VAULT INSTALLATION

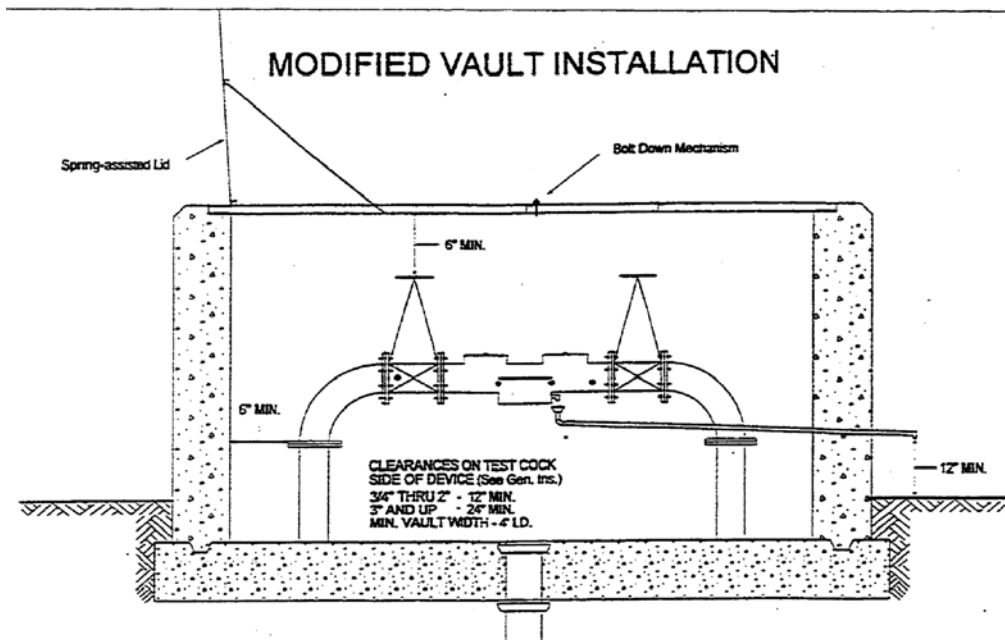
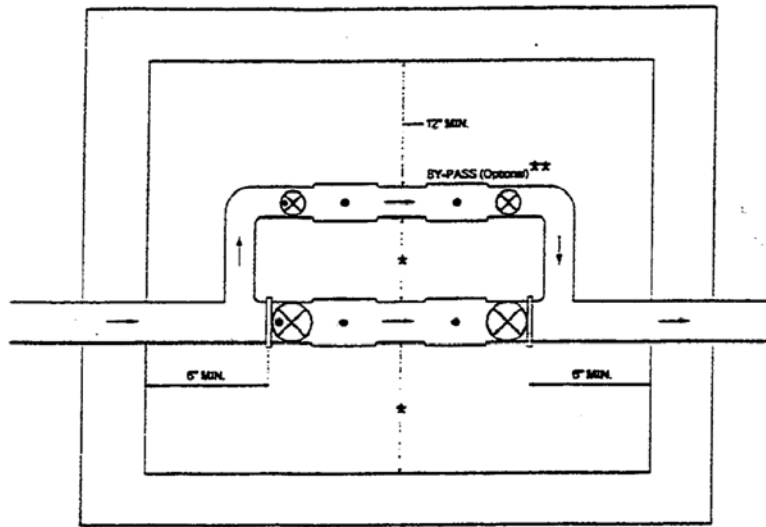

FIG. B

III. INSTALLATION OF DOUBLE CHECK VALVE ASSEMBLY BACKFLOW PREVENTER

Though double check valve assemblies can be installed above ground, these backflow preventers are also readily adaptable for vault installations. Special notice should be given to the side clearances for accessibility to properly test and repair the assembly. Test cocks must be plugged. Plugs must be non-ferrous, e.g., brass, plastic, etc. NOTE SIDE CLEARANCES, (Fig. C) (See General Instructions, page 1)

VAULT INSTALLATION



TOP VIEW

CLEARANCES ON TEST COCK
SIDE OF DEVICE (See Gen. Ins.)
3/4" THRU 2" - 12" MIN. *
3" AND UP - 24" MIN.
MIN. VAULT WIDTH 3" AND UP - 4" I.D.

* SEE III A - 3/4" THRU 2"
** SEE V - BY-PASS POLICY

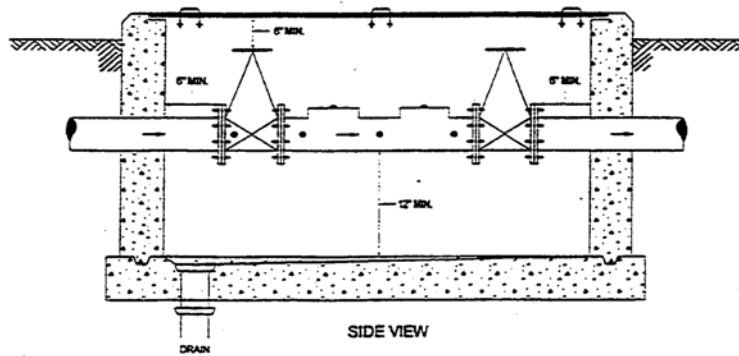

SIDE VIEW
Fig. C

III.

A. BELOW GRADE VAULT INSTALLATION OF DOUBLE CHECK VALVE ASSEMBLY

Double check valve assemblies should be installed above grade if possible, but may be installed in below grade vaults when these vaults are properly constructed in accordance with the following guidelines:

I. General – Double Check Valve Assemblies – All Sizes

Double check valve assembly backflow preventers, unlike reduced pressure principle assemblies, are designed and readily adaptable for below grade installations, provided they are installed in a vault which is well drained and of solid construction. Vaults within traffic areas should be constructed accordingly. Assemblies must be installed horizontally and in an upright position. Backflow preventers installed in a vertical position or on their side will be disapproved.

II. Double Check Valve Assemblies Sizes ¾” through 2”

Backflow preventers of sizes two inches and less should not be installed more than 12” below grade for accessibility during testing and repair. To accommodate the installation of most double check valve assemblies up to and including two inch sizes, a vault constructed of concrete, steel, cast iron or other durable material conforming to the dimensions described below is acceptable provided a twelve inch (12”) clearance is maintained on the test cock side of the assembly (see General Instructions No. 4), a four inch (4”) clearance on the non-test cock side and a four inch (4”) clearance between the two gate valves and the ends of the vault. Exception: On 1” or smaller double check valve assemblies that are repairable from the top, have test cocks on the top of the assembly and not installed in cement or asphalt, the side clearance can be reduced to 4”, see General Instructions No. 4. The floor of the vault shall be either of solid construction with a drain or bottomless to facilitate drainage. In order to facilitate repair of Y-pattern assemblies, a twelve inch (12”) clearance must be provided below the assembly. Rigid construction must extend to the floor of the vault.

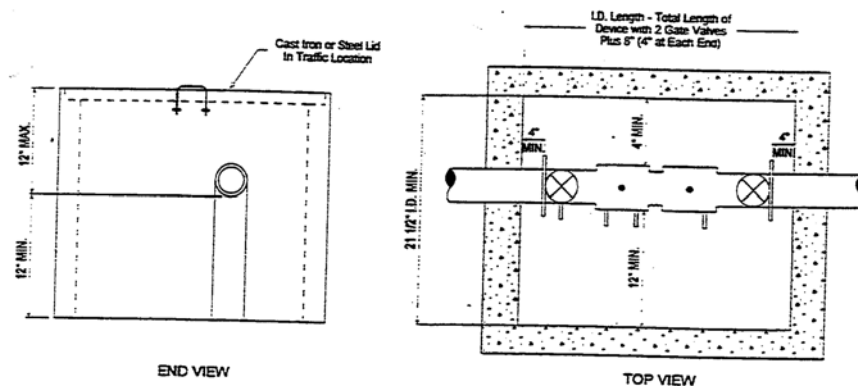

IV. INDOOR INSTALLATION – REDUCED PRESSURE AND DOUBLE CHECK VALVE ASSEMBLY BACKFLOW PREVENTERS

Where it is impractical to install the backflow preventer above ground, the installation may be made in an easily accessible location inside a building. The unit should be placed above the floor and away from the wall, at a distance great enough to allow clearance for repair work. If the backflow preventer is positioned against the wall, care should be taken that the test cocks are easily accessible for testing, and the assembly can be repaired. An air gap should be used between the relief valve outlet and the drain line if drainage is to be piped away. The drain should be of adequate size to carry the volume of water the relief valve is capable of discharging. The air gap should be no less than double the diameter of the discharge pipe. (Fig. D) (See General Instructions, Page 1)

INDOOR INSTALLATION

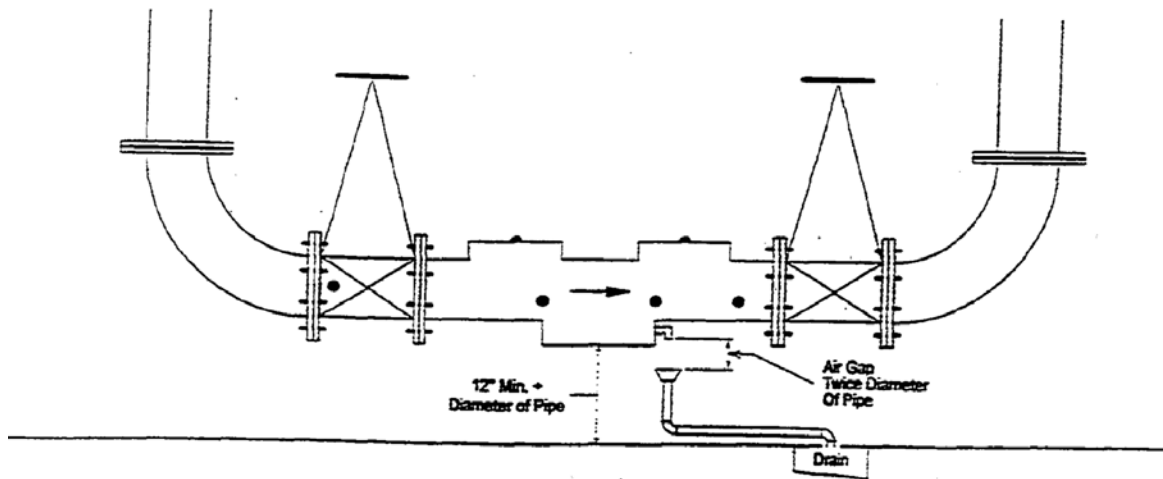

FIG D.

V. BY-PASS POLICY

Backflow prevention assemblies must be tested upon installation and on an annual basis thereafter. The testing procedure requires the water to be turned off. If continuous water service is a necessity, provisions should be made for a by-pass around the mainline backflow preventer. A by-pass installed around an approved backflow prevention assembly must be protected from backflow through this by-pass, i.e., it also will include a backflow preventer of the same type as the main service line backflow preventer. Though it need not be of the same size, it must be installed in a similar fashion to the service line device.

VI. AIR GAP SEPARATION (A/G)

An air gap separation means the unobstructed vertical distance through the free atmosphere between the lowest opening from any pipe or faucet supplying water to a tank, plumbing fixture or other device and the flood level or overflow rim of the receptacle. An "approved air gap separation" shall be at least double the diameter of the supply pipe measured vertically above the overflow rim of the vessel and in no case shall the gap be less than 1." The tank should be installed as close to the property line as practical. The piping between the water meter and the air gap separation should be entirely visible to ensure that no connections or tees are made in that area. To eliminate possible entrance of vermin, screened protections over the entire (A/G) set up are encouraged. (See General Instructions, Page 1)

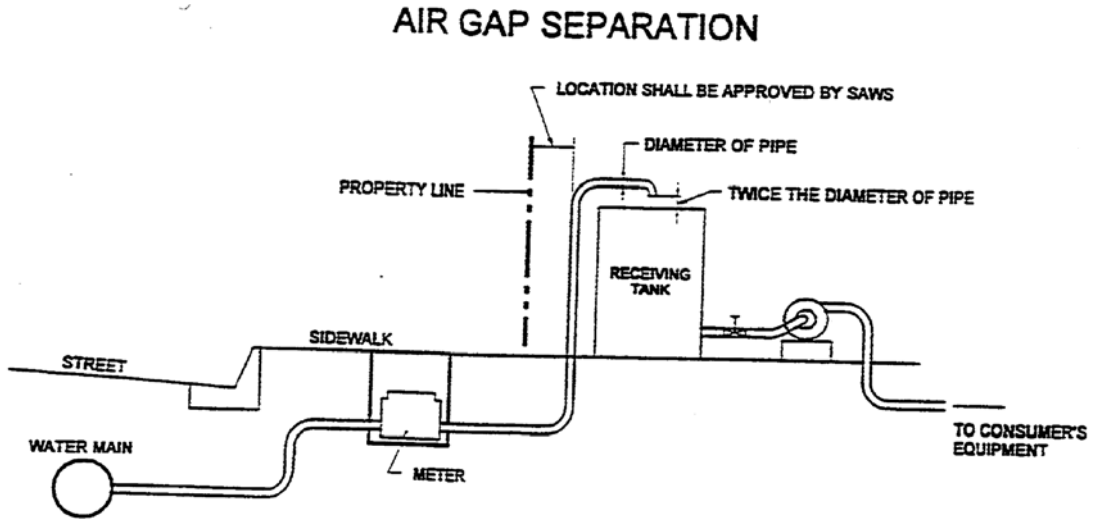
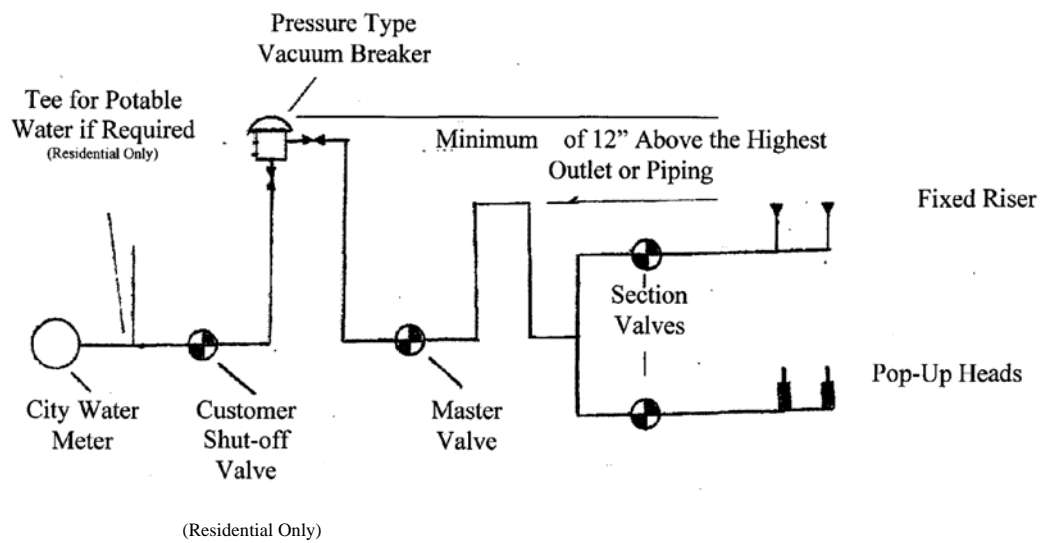

FIG E.

VII. LAWN SPRINKLER INSTALLATION USING A PRESSURE TYPE VACUUM BREAKER AS A BACKFLOW PREVENTER

Pressure type vacuum breakers may be installed without regards to down stream valve, making it possible to isolate an entire lawn sprinkler system with a single unit when properly located. This assembly must not be installed where it will be subject to backpressure and should be installed at least twelve inches (12") above the highest outlet. The vacuum breaker should be installed where it will be accessible for periodic testing and where, if slight spillage should occur, it would not be objectionable. (Fig. F) (See General Instructions, Page 1). If chemical additives are to be used, an air gap separation or reduced pressure principle assembly will be required.



BACKFLOW PROTECTION FOR WATER HAULING
EQUIPMENT AND/OR MIXING TANKS

1. PUPOSE

The following information is provided in the interest of protecting the potable water system from actual or potential contamination through cross connections and backflow situations. A cross-connection is any connection between the potable water supply and another water supply of unknown quality or any source, which may contain contaminating or polluting substances. All water hauling equipment and/or potable water mixing tanks using water from fire hydrants or any other type outlet must use one of the backflow prevention methods described herein to adequately protect the potable water system.

2. GENERAL REQUIRMENTS

- a. The customer must contact the San Antonio Water System's Backflow Prevention section of the Pipeline Inspections Department at (210) 233-3332 prior to water usage to request an inspection of the on-site or vehicular backflow protection installed. Requests made between 8:00 am and 11:00 am, should normally result in same day inspections, otherwise the inspections will be made the following business day, consistent with operational requirements.
- b. Customers electing to permanently install an air gap separation on water transporting vehicle(s) must have the air gap separation inspected and approved by the Inspections Division.
- c. Customers electing to install a reduced pressure principle backflow assembly will be required to have the assembly tested by a Licensed backflow prevention assembly tester upon installation and minimum of annually thereafter.

3. BACKFLOW PREVENTION METHODS

The customer shall provide one of the approved methods for backflow protection described below and as further illustrated in the attached drawings marked as figures A through D. The customer shall also consult the San Antonio Water System list of approved assemblies and installation guidelines.

- a. Air gap separation provided by a metallic pipe permanently installed on the water transporting vehicle which will serve as a fill line and also include a hose connection to the potable water outlet. Note figure A.
- b. Air gap separation installed on the outlet side of the fire hydrant meter. Note figure B.
- c. Reduced Pressure Principle (R/P) backflow prevention assembly installed at the fire hydrant meter. Note figure C.
- d. Reduced Pressure Principle (R/P) backflow prevention assembly permanently installed on the water-transporting vehicle. Note figure D.

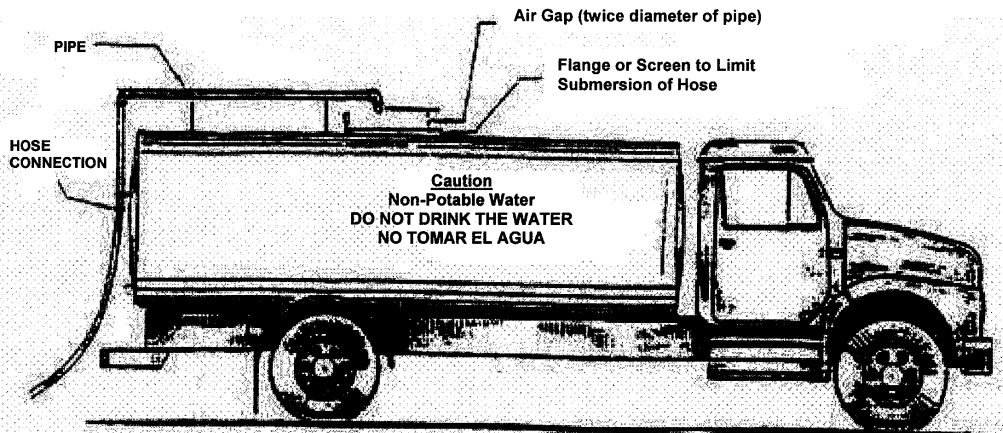

Figure A

Must have Signs Stating
"Caution: Non-Potable Water.
Do not Drink the Water
NO TOMAR EL AGUA"

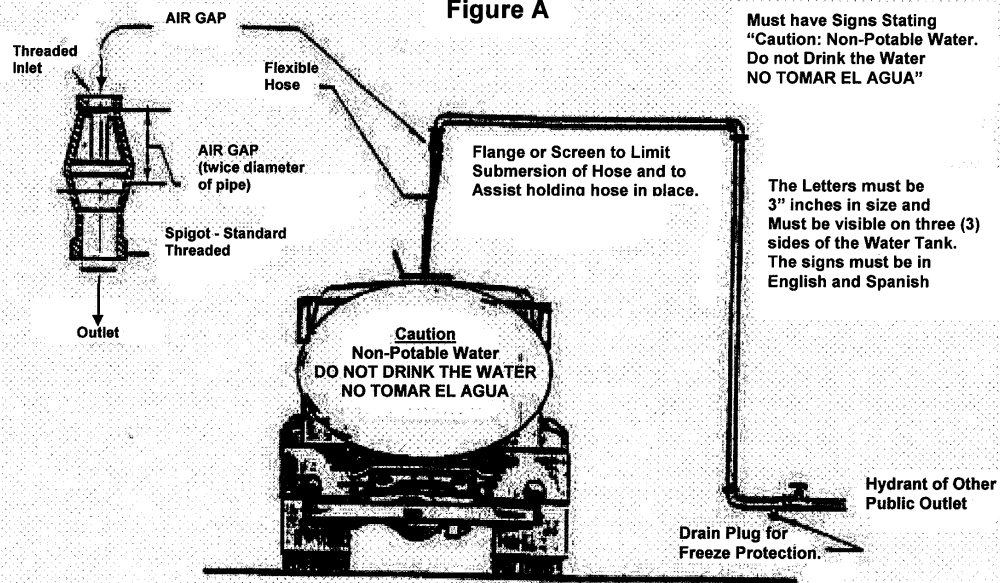

Figure B

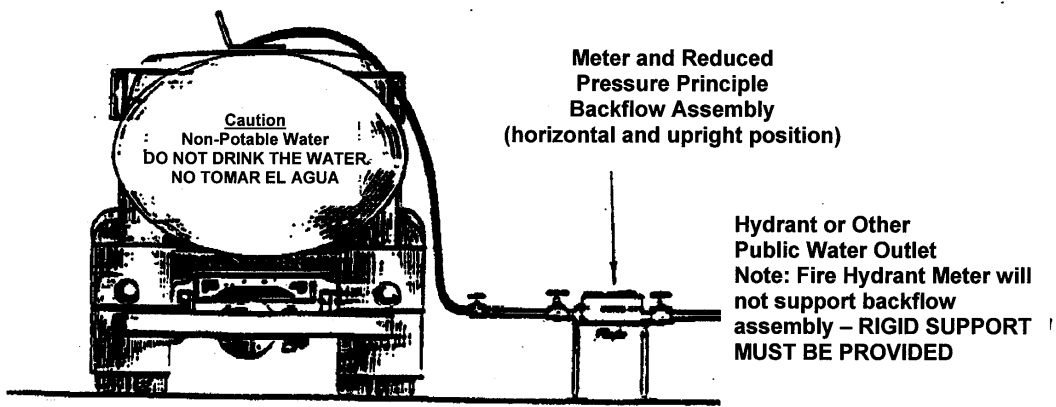

Figure C

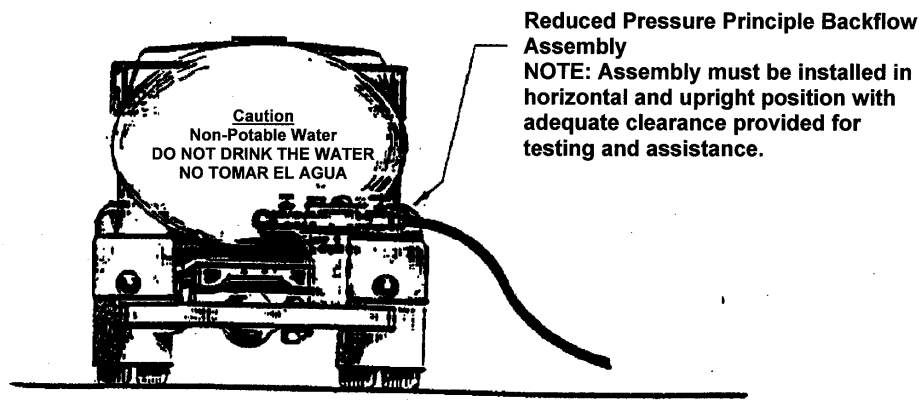

Figure D

Backflow Prevention Method-Reduced Pressure Principle Assembly

SAWS

Backflow Prevention

Standard Drawing Detail Information

The Standard Drawing Detail Information can be found on saws.org. From the home page go to:

BUSINESS CENTER : SPECIFICATIONS : CONSTRUCTION SPECIFICATIONS

LOOK FOR THE DESIRED DETAILED DRAWING BY THE DD NUMBER.

OR

CONTACT SAWS

AT

Mr. Bruce Rathburn
Backflow Section
San Antonio Water System
2800 U.S. 281 North
Customer Service Center, Tower II
San Antonio, Texas 78212
(210) 233-3332